

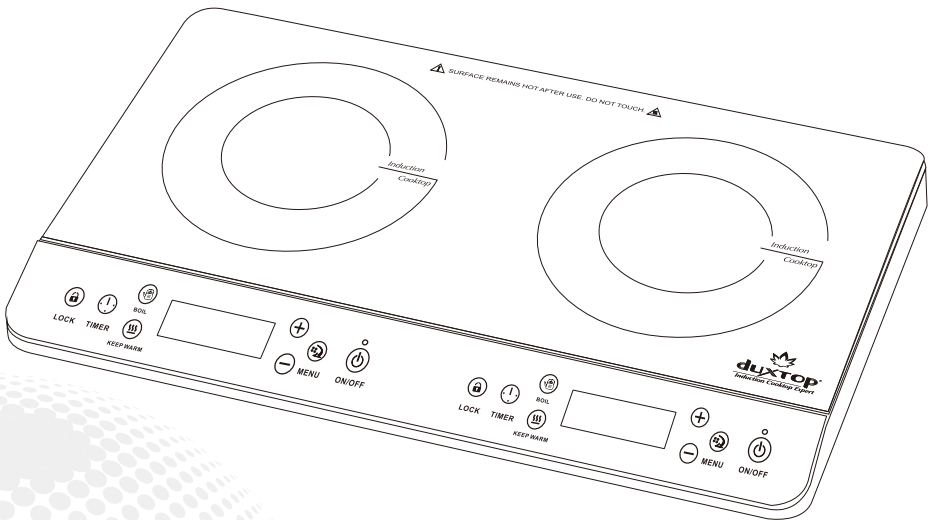

# PORTABLE DOUBLE INDUCTION COOKTOP



## User Manual

Model: BT-350DZ  
Model: 9620LS

SN: 871M



# Welcome to the Secura Family!

Congratulations on being the proud owner of your new Secura product. We believe in manufacturing only the highest quality kitchen, home and personal care products for our customers. We are a U.S.-based manufacturer and all our products meet strict standards for manufacturing, safety and performance.

We also believe in providing the best customer service and support in the industry. That is why we offer a two-year warranty on this product that ensures your satisfaction - so you can enjoy it for years to come.

If you have questions or need assistance, please email [CustomerCare@thesecura.com](mailto:CustomerCare@thesecura.com). For fastest response, please include product name and model #, proof of original purchase, complete contact information, and detailed information about the issue, including pictures when applicable.

Your feedback and suggestions are also important to us, so please email them to us at [CustomerCare@thesecura.com](mailto:CustomerCare@thesecura.com).

The Secura Team



**Copyright 2018-2022 Secura, Inc. All rights reserved.**

The material in this publication is protected under International and Federal Copyright Laws and Treaties, and as such, any unauthorized reprint or use of this material is strictly prohibited.

No part of this book may be reproduced or transmitted in any form without the written permission of the author, except for the inclusion of brief quotations in a review.

Reproduction or translation of any part of this work without the permission of the copyright holder is against the law.

## TABLE OF CONTENTS

IMPORTANT CAUTIONS, WARNINGS AND SAFEGUARDS .....	1
PARTS IDENTIFICATION .....	4
SELECTING THE PROPER COOKWARE .....	5
OPERATING INSTRUCTIONS .....	6
CARE AND MAINTENANCE .....	10
TROUBLESHOOTING GUIDE & CUSTOMER SERVICE .....	11
COMMONLY ASKED QUESTIONS .....	13
SPECIFICATIONS .....	14
DISPOSAL .....	14
CONTACT .....	14
MANUFACTURER'S LIMITED WARRANTY .....	15

# PORTABLE DOUBLE INDUCTION COOKTOP



**To reduce the risk of fire, injury or electrical shock along with extending the life of your cooktop, please read and follow all of the information in this manual before using and save it for future reference.**

## IMPORTANT CAUTIONS, WARNINGS AND SAFEGUARDS

Before operating your new duxtop® Induction Cooktop, basic safety precautions should always be followed, including the following:

- Read this manual before using the cooktop.
- To protect against fire, electric shock and injury to persons, do not submerge the cooktop unit or electrical cord in liquid.
- Do not touch the unit with wet hands, or use in a wet outdoor environment.
- Do not expose to humidity for extended periods.
- Never operate the unit if cooktop surface, electrical cord or plug is damaged.
- Do not let cord hang over edge of table or countertop, or touch hot surfaces.
- To protect against electrical hazards, do not move the unit by pulling on the power cord.
- Only qualified experts may perform repair and maintenance work on the cooktop unit. Never disassemble or attempt to repair the cooktop yourself.
- Do not touch the cooktop surface or cookware bottom for several minutes after using as both will be hot.
- Do not move the cooktop unit while cooking or with hot cookware on cooktop surface.
- Never place any metal objects on the cooktop surface other than authorized metal cookware or an Induction Interface Disk.
- To protect against fire, do not operate the cooktop in or around flammable or explosive environments.
- Do not place the cooktop on any metal surface as the surface could become hot.
- Do not heat unopened cans of food as they could expand and explode.
- Do not allow children to handle or operate the unit at any time.
- Do not use the unit to heat or warm the room.
- Never heat empty containers on the cooktop surface.
- Remove cookware from cooktop when the unit is not in use.
- Do not place any metal object other than cookware on the cooktop surface.
- Keep at least 4" from walls or other objects for proper ventilation. Do not block the rear and sides of the unit.

- Do not place objects weighing more than 25 pounds on the cooktop surface.
- Keep the cool air inlet and fan free from blockages.
- Do not clean a duxtop® induction cooktop in a dishwasher.
- This unit is for household use only. Not for commercial use. Do not use the unit for anything other than its intended purpose.
- Do not place objects affected by a magnet, such as a credit card, radio, television, etc., within 10 feet of the cooktop while operating the unit.
- To avoid circuit overload, do not operate another electrical appliance on the same outlet or circuit.
- Do not place any combustible material such as paper or towels, near or on the cooktop while it is in use or hot.
- Do not operate on other appliances or devices, including but not limited to stove range, oven, etc.
- Do not operate on heated or hot surface.
- Save this User Manual.



**CAUTION:** This cooktop unit emits an electromagnetic field, therefore people with pacemakers should consult with their physician before using.



To avoid circuit overload, do not operate another electrical appliance on the same outlet or circuit.

## Warning

**Changes or modifications to this unit could void the user's warranty.**

## PORTABLE DOUBLE INDUCTION COOKTOP



To avoid circuit overload, do not operate another electrical appliance on the same outlet or circuit.



Always follow basic safety precautions when using any electrical products, especially when children are present.



**CAUTION: HOT SURFACES** - This appliance generates heat during use. Proper precautions must be taken to prevent the risk of burns, fires or other injury to persons or damage to property.

**HOUSEHOLD USE ONLY**  
**DO NOT IMMERSE IN LIQUID**  
**SAVE THESE INSTRUCTIONS**

# PARTS IDENTIFICATION

**COOKTOP SURFACE**

**COOKWARE ALIGNMENT GUIDE**

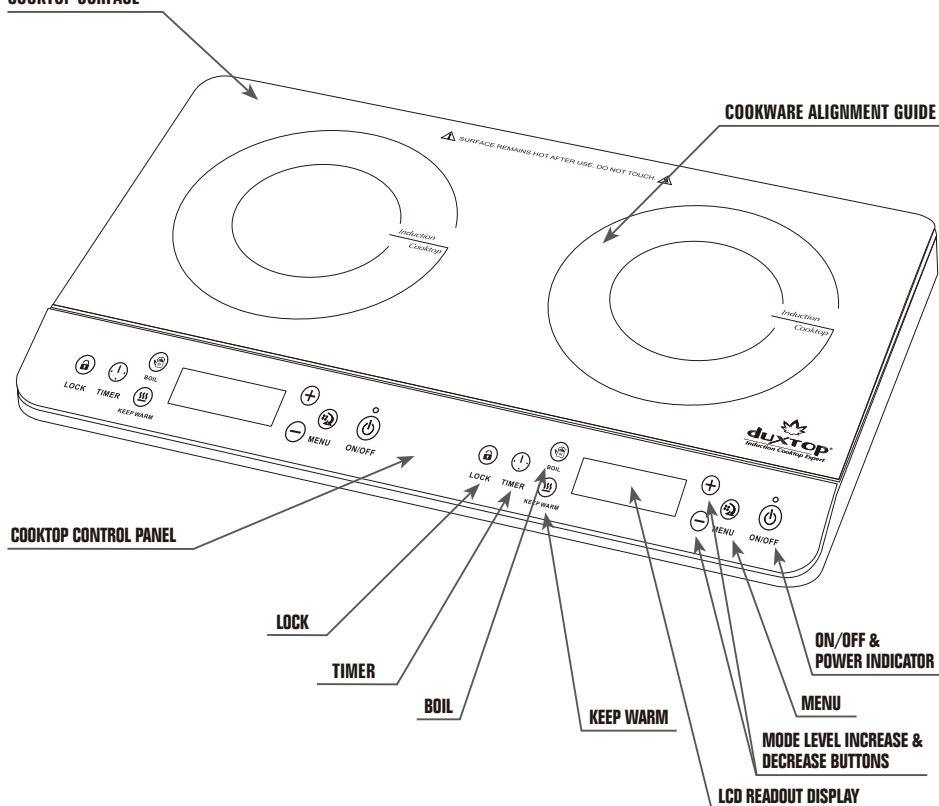



# PORTABLE DOUBLE INDUCTION COOKTOP

## SELECTING THE PROPER COOKWARE

Your induction cooktop will not operate without the compatible cookware. Read the following information in this section carefully to get the maximum efficiency from your cooking unit. The rule of thumb for selecting cookware is, if a magnet sticks to the cookware bottom, the cookware will work on your duxtop® induction cooktop.

### The bottom surface of the cookware must

- Be made of a ferrous magnetic material. If the cookware bottom is made of material with low ferrous magnetic content the "E0" error code may display, indicating cookware is not suited for induction cooking.
- Have a flat bottom surface with a minimum bottom diameter of 5". The diameter and thickness of the cookware's magnetic layer needs to be large enough to catch the magnetic wave, otherwise the cooktop may not operate (displays "E0" error code).
- Touch the cooktop or rise no more than 1" above it.

### SUITABLE COOKWARE MATERIAL

- cast iron;
- iron;
- magnetic steel;
- enameled iron,
- stainless steel manufactured with a magnetic bottom

**DO NOT** use cookware made out of:

- Glass
- Ceramic
- Copper
- Aluminum
- Non-magnetic stainless steel (18/10, 18/8) bottom

# OPERATING INSTRUCTIONS

**CAUTION: ALWAYS USE A DEDICATED OUTLET.** This unit is designed to operate using a 110/120V electrical outlet having a 15 amp capacity. This is a high draw appliance and should not share an outlet or circuit with any other electrical appliance.

- Place the unit on a dry, stable, level and non-combustible, non-metallic surface.
- Allow at least 4 inches of space around the whole cooktop unit for proper ventilation.
- Plug the POWER CORD into a 120V/15 amp electrical socket. The unit will "beep" and the POWER INDICATOR light will illuminate red.
- Before turning the cooktop on, make sure the ingredients are in the compatible cookware and the cookware is centered on the COOKWARE ALIGNMENT GUIDE.
- Once the cooktop is plugged in, it is a simple two-step process to power on the cooktop. Press the "ON/OFF" button, the cooktop will cycle "ON", the COOL AIR FAN will start and the LCD display screen will light showing a series of dashes. Press the "MENU" button, the cooktop will activate at the default power setting of 5.0.
- After cooking is completed, press the "ON/OFF" button to turn the unit off. The LCD screen will turn off, however "HOT" will display and the COOL AIR FAN will continue to run for a short time to cool the unit. The word "HOT" will only appear on the display if the cooktop has reached a pre-programmed internal temperature. The fan however, will remain on regardless of temperature once the unit is turned off.
- If the cooktop unit does not operate as intended, see the "TROUBLESHOOTING GUIDE" section in this manual.

## Operation Modes

This unit offers both Power and Temperature Modes for convenient and efficient cooking along with an automatic 10-hour timer:

### POWER MODE OPERATION

The Power and Temperature Mode functions work independently of each other. The power level selected directly relates to the amount of wattage, or the BTU/HR equivalent, the cooktop generates. To increase the cooking speed, select a higher power level.

The default power level setting is 5.0. Press the + or – buttons to adjust power levels from 0.5 to 10. If the "E2" error code is displayed during cooking, the cookware bottom has exceeded 460 °F, switch to Temperature Mode at this time.

### TEMPERATURE MODE OPERATION

The Temperature Mode should be used when a specific cooking temperature is required. Once the cookware has reached the selected temperature, the unit will cycle to maintain the selected cooking temperature.

The default temperature level setting is 300 °F. Press the + or – buttons to adjust the temperature setting. Use the Temperature Mode when specific temperatures must be maintained. This mode has 20 temperature settings ranging from 100 °F - 460 °F (37.8 °C - 238 °C).

# PORTABLE DOUBLE INDUCTION COOKTOP

## Additional Preset Function Buttons:

- **LOCK** - The “LOCK” button allows you to lock-out all the other buttons and is a convenience and safety feature. It is designed to keep the cooking and timer settings from being accidentally changed once they have been set. The “LOCK” feature DOES NOT lock the ON/OFF button, so the cooktop can always be shut off if needed.
- **BOIL** - If you press the “BOIL” button, the unit will switch to POWER MODE level 10 and the timer will be automatically set to 10 minutes. When the timer has expired, the unit will “beep” and the cooktop will turn off. If the volume of water has not reached a full boil, please restart the BOIL function.
- **KEEP WARM** - If you press the “KEEP WARM” button, the unit will switch to TEMPERATURE MODE at 140 °F with the timer set for 30 minutes.

Power Level \ Watts	Left	Right
0.5	100*	
1.0	180*	100*
1.5	260*	
2.0	340*	200*
2.5	420*	
3.0	500*	300*
3.5	580*	
4.0	660*	400
4.5	740*	
5.0	800	500
5.5	900	
6.0	1000	600
6.5	1100	
7.0	1200	700
7.5	1300	
8.0	1400	800
8.5	1500	
9.0	1600	900
9.5	1700	
10	1800	1000

Temp Setting	Temp (F)	Temp (C)
1	100	38
2	120	49
3	140	60
4	160	71
5	180	82
6	200	93
7	220	104
8	240	116
9	260	127
10	280	138
11	300	149
12	320	160
13	340	171
14	360	182
15	375	191
16	390	199
17	405	207
18	420	216
19	440	227
20	460	238

\* Power Mode settings 0.5 - 4.5 use power cycling. The number shown is the average number of watts.

Power Mode settings above 5.0 use continuous control.

## POWER MODE vs. TEMPERATURE MODE

Switching between Power Mode and Temperature Mode is accomplished by pressing the “MENU” button. If a specific cooking temperature is not required, we suggest using Power Mode instead of Temperature Mode. To quickly bring a pot of water to boil, use a higher power level setting or simply press the “BOIL” button. For frying or browning food, Temperature Mode is preferred because the built-in microprocessor monitors and regulates the cookware temperature to the preset temperature. Frying or browning food using Power Mode may overheat the cookware, and in some cases, extremely high temperatures may damage your cookware or cooktop. The duxtop(c) induction cooktop has a built-in safety mechanism to detect such situations and the unit can switch to Temperature Mode from Power Mode automatically when overheating is detected. When this happens it is an indication that Temperature Mode may be more suitable for your current cooking task. When two burners are in Temperature Mode, they work independently of each other and both can reach the maximum temperature, 460 °F and will not exceed it.

### Limitations of Temperature Mode:

Like all other cooktops with a glass cooktop, the temperature sensor is located underneath the glass top. As a result, and that different cookware yields different temperatures, the temperature readout is only an estimate of the actual cooking temperature. It is accurate enough for daily cooking requirements. The temperature in your pan may be different than the setting you have selected. Please test a few times to find the proper temperature setting for your particular cooking task and cookware.

### Power Sharing Feature:

Power sharing technology is a safety and efficiency feature. It is designed to avoid electrical hazards and increase efficiency by allowing the burners to share power between them when they are in Power Mode. When operating only one burner, the maximum power of the left burner is 1800W and the right is 1000W. They do not have equal power.

When operating both burners, their maximum COMBINED power is 1800W. When operating both burners at the same time, increasing the power level of one burner will cause the other burner to self-adjust, and decrease if needed, in order not exceed 1800W. (i.e. if the left burner is set to 1000W, the right burner will operate at a maximum of 800W.)

Please refer to the table below for more details about the Power Sharing feature.

Left	Power Level	0.5	1.0	1.5	2.0	2.5	3.0	3.5	4.0	4.5	5.0	5.5	6.0	6.5	7.0	7.5	8.0			8.5	9	9.5	10.0		
	Watts	100*	180*	260*	340*	420*	500*	580*	660*	740*	800	900	1000	1100	1200	1300	1400			1500	1600	1700	1800		
Right	Power Level	10.0											9.0	8.0	7.0	6.0	5.0	4.0	3.0	2.0	1.0	0			
	Watts	1000											900	800	700	600	500	400	300*	200*	100*	0			

\* Average watts with power cycling.

## PORTABLE DOUBLE INDUCTION COOKTOP

**Note:** When using the left burner in Power Mode level 8.5 (1500W) or greater, the right burner will not work. This is because the right burner requires a minimum of 400 watts to be available to operate. The combination of 1500W plus 400W would exceed the 1800W rating for this cooktop.

When the left power level is in 8.5 or greater, press the "+" button of the right burner, it will activate at the power level of "1.0" or press the "MENU" button of the right burner to switch to Temperature Mode, the right burner will activate at the temperature setting of 300 °F. When the left burner is in 8.5 (1500W) or greater, the temperature readout of right burner will flash in each temperature setting, indicating the right burner does not work. To enable the Temperature Mode of the right burner, please turn down the left power level to 8.0 or below. However, when using the left burner in Power Mode level 8.0, the actual temperature of the right burner may take longer to reach the setting temperature due to the power sharing with the left burner.

Both Power and Temperature Modes will be impacted by this safety feature. Selecting Power Mode 8.5 or higher on the left burner will cause the right burner to go into standby and display "0".

### 10-HOUR AUTOMATIC TIMER

The automatic timer may be used with either the Temperature or Power Mode. Press the "TIMER" button to activate the timer. The TIMER portion of the LCD display will activate and 0:00 will appear in the LCD READOUT DISPLAY. The :00 minutes portion of the readout will be blinking, indicating the minutes can be set. Press the + or – button until the desired number of minutes appears. Wait 5 seconds and the 0: hours side of the readout will begin to blink. This indicates you may now set the number of hours for the timer. Press the + or – key to set the number of hours. 5 seconds after you have set the hours portion of the timer, the numbers will stop blinking and timing will start. If you do not enter an amount of time into the AUTOMATIC TIMER within 10 seconds the feature will shut off and the timer will not be set.

The + and – buttons can be "tapped" to increase or decrease the minutes/hours by 1 minute/1 hour increments or they can be held down for rapid increase or decrease of time, as necessary.

The timer may be reset at any time during operation by pressing the "TIMER" button again. When the timer has expired, the unit will "beep" and the cooktop will turn off.

### AUTOMATIC SHUT OFF

Unless the timer has been set, this cooktop will shut down automatically in 120 minutes. This is a safety feature in compliance with safety regulations.

**NOTE:** The cooktop unit will automatically shut off and "beep" if either:

- the wrong type of cookware is put on the cooktop
- no cookware is placed on the unit ("E0" will flash on the LCD screen) or
- the unit is turned on and the "MENU" button is not pressed

## CARE AND MAINTENANCE

The cooktop is easy to maintain. Use a moist cloth with a mild liquid detergent to wipe off grease and stains, and then let dry. Protect the cooktop from dust by covering it when not in use.

Things to avoid doing.

**DO NOT:**

- clean the COOKTOP SURFACE with metal scouring pads, abrasives, or solvents
- immerse cord or cooktop unit in water or other liquids
- keep the unit plugged in while cleaning it
- keep the unit plugged in when not in use
- store or clean the unit while still hot
- place objects heavier than 25 pounds on the COOKTOP SURFACE
- use the unit if the COOKTOP SURFACE or POWER CORD is damaged
- keep the cooktop unit on or near other heat sources

## TROUBLESHOOTING GUIDE & CUSTOMER SERVICE

If after reviewing the troubleshooting guide the problem is not resolved, do not attempt to repair the unit yourself. Please contact us at [CustomerCare@thesecura.com](mailto:CustomerCare@thesecura.com) for assistance.

**PROBLEM** - After plugging in the power cord, the POWER INDICATOR LIGHT does not illuminate red:

- The plug may be loose in the electrical outlet or
- The circuit breaker may be inoperative or tripped

**PROBLEM** - The POWER INDICATOR LIGHT is lit, but the fan is not running, nor is the cookware heating up:

- Press the "MENU" button
- The wrong type of cookware (non-magnetic) is being used
- The pan is not centered on the COOKTOP ALIGNMENT GUIDE correctly
- The COOKTOP SURFACE may be cracked

**PROBLEM** - The induction cooktop suddenly stops heating during operation and shuts down:

- The cooktop unit shuts down due to the overheating sensor detecting an excessively high surface temperature. The cause may be heating empty cookware or cooking at a high power setting for too long
- A blocked COOL AIR INLET & FAN or WARM AIR OUTLET caused the cooktop to overheat;
- The unit was unplugged while in use
- The fuse or circuit breaker tripped during use (Do not plug other appliances into the same circuit while using the cooktop)

**PROBLEM** - The Induction cooktop switches from Power Mode to Temperature Mode automatically:

- This is a safety feature. The unit switches to Temperature Mode (140 °F) when the cookware is overheated under Power Mode. This is most likely to occur when you are frying or sautéing food. These cooking methods involve high heat and need a regulated temperature within a certain range. If the temperature is too low, it may not cook your food properly, if the temperature is too high, it may burn your food. Once in Temperature Mode you can adjust the temperature to the appropriate setting that fits your cooking task. For information about when to use Power Mode or Temperature Mode, please refer to POWER MODE VS. TEMPERATURE MODE section in this manual.

## Error code guide

If an error code appears in the LCD READOUT DISPLAY, follow the Instructions in the ERROR CODE table (below) to correct the problem:

ERROR CODE	PROBLEM	REMEDY
E0	No cookware is detected, incompatible cookware is detected or cookware is not centered on the COOKWARE ALIGNMENT GUIDE.	If no cookware is on the cooktop, place cookware on the top within 1 minute. If incompatible cookware is detected replace it with proper cookware. If the cookware is misaligned, move it within the COOKWARE ALIGNMENT GUIDE. The unit will shut down automatically if none of these actions are taken.
E1	Excessive high temperature, cooking fan malfunction, or inadequate ventilation for the cooktop.	Unplug the cord from the electrical outlet. Ensure proper ventilation by making sure the fan is at least 4" away from any obstruction. Wait 10 minutes for the cooktop and cookware to cool down and then plug it back into a 120V electrical outlet. Turn the unit back on and listen for the fan to confirm it is running.
E2	Cooking surface temperature exceeds 460 °F (238 °C) limit and the unit shuts down automatically.	This is a safety feature to prevent the cooking surface from overheating. It usually happens while using POWER Mode, when the cookware bottom is above 460 °F (238 °C). Extremely high temperatures could damage your cookware and cooktop. If E2 error code happens during frying or sautéing while using POWER Mode, switch to TEMPERATURE Mode. If E2 happens while boiling water, unplug the unit from the electrical outlet, wait 10 minutes for the cooktop and cookware to cool down and reconnect the cord to the outlet. Turn the unit back on, listen for the fan to start and ensure the unit is at least 4" away from any obstructions.
E3	Voltage input is too high or too low and the unit shuts down.	Unplug the cord from the electrical outlet. Verify the voltage is 110/120V AC with a voltage tester. If not, switch to a different electrical outlet with the proper voltage level before operating the unit.

**Note:** If any of the above remedies fail to correct the problem, please contact CustomerCare@thesecura.com.



## COMMONLY ASKED QUESTIONS

### What are Induction cooktop advantages?

To serious cooks, the most important advantage of induction cooktops is that you can adjust the cooking heat instantly and with great precision. The induction cooktop uses a standard 110/120 volts of electrical power and plugs into a standard household electrical outlet. Because duxtop® cooktops produce up to 1800 watts of power, they are almost 50% more powerful than gas stoves and heat up to temperature nearly twice as fast as electric cooking elements, yet they do not require the high amperage of 220-volt power not commonly found in household kitchens.

### Is induction cooking more efficient than gas?

With an 83% energy efficiency, induction cooking is more efficient than both electric or gas. While gas burning cooktops are only 30-35% efficient and cost approximately \$1.65 per hour to operate, an induction cooktop costs only \$0.12 per hour to operate.

### How safe is induction cooking?

Because there is no open flame or hot cooking element, the induction process produces heat only within the cookware. The cooktop surface remains cool except for the heat transferred from the bottom of the cookware to the glass surface (immediately below the cookware).

### What are the electrical power requirements?

Double burner induction units designed for household use in the U.S. market are all capable of operating efficiently on a standard 110/120-volt outlet. It is strongly recommended to dedicate an outlet for each individual unit when being used since each unit will draw about 15 amps, the amperage of most common household electrical outlets.

### What type of cookware can I use?

The general rule of thumb is, if a magnet sticks to it, it will work with the duxtop® cooktop. Cookware made from cast iron, iron, enameled steel or iron, or magnetic stainless steel work very well. duxtop® offers a large selection of Whole-clad Tri-ply Induction Ready Premium Cookware™.

### How is induction cooking different than electric cooking ?

Induction units place the electrical energy directly into the cookware without using energy towards a heating element. Regular electric cooking elements use energy to heat the heating element and then through conduction, the heat is transferred to the cooking pan.

Induction cooking heating is very fast and responsive to temperature control changes making them even faster and more efficient than gas cooking. Resistance-type heating elements are very inefficient and are slow to respond.

### Is it easy to use?

The rapid heating of the cookware makes all kinds of cooking fast and easy, especially when warming, sautéing, frying, and boiling pasta. Cleaning a duxtop® induction cooktop unit is easy. With no open flame or heating element, food does not burn-on so you can just wipe the cooktop surface clean with a damp towel.

## SPECIFICATIONS

<b>Model</b>	BT-350DZ / 9620LS	
<b>Power Source</b>	120V/60Hz 15 amp circuit	
<b>Output</b>	Left:100-1800W	Right: 100-1000W
<b>Power Levels</b>	Left: 0.5-10 (20 settings)	Right: 1.0-10 (10 settings)
<b>Temperature Range</b>	100°F- 460°F (37.8°C-238°C) (20 settings)	
<b>Weight</b>	12lbs. 7.7oz	
<b>Dimensions</b>	23.9"X14.2"X2.4"	
<b>Cord Length</b>	5 ft.	

## DISPOSAL



When this appliance has reached the end of its life, please dispose of the unit properly.

This and other electrical appliances contain valuable materials that can be recycled.



Electronic waste may be harmful to our environment if not disposed of properly.

We ask that you follow your governing agency's rules and regulations when disposing of electronic appliances. Please find an authorized recycling facility near you.

## CONTACT

If you have any questions or concerns not addressed in this user manual, please contact our Customer Service Department at 888-792-2360 (North America) or email us at [CustomerCare@thesecura.com](mailto:CustomerCare@thesecura.com).

Please read the operating instructions before using this product.

Please keep the original box and packaging materials in the event that service is required.



## ***Manufacturer's Limited Warranty***

The Manufacturer of this product warrants to the original purchaser of this product that this product will be free from defects in material and workmanship under normal use and service for 2 years from date of purchase. Manufacturer will, at its option, repair or replace with a new or refurbished product. Providing a replacement product does not renew or extend the warranty period from the original date of purchase. The Manufacturer reserves the right, before having any obligation under this limited warranty, to inspect the product, and all costs of shipping the product for inspection and warranty service shall be borne solely by the purchaser.

For the fastest processing of a warranty claim, the Purchaser should e-mail [CustomerCare@thesecura.com](mailto:CustomerCare@thesecura.com) and include the product name and model #, proof of original purchase, complete contact information, and detailed information about the issue, including pictures when applicable.

The manufacturer's limited warranty is valid only in accordance with the following conditions:

1. The product is purchased directly from manufacturer or an authorized reseller or distributor.
2. Only the original purchaser is covered by this warranty. This warranty is not transferable.
3. Product is for personal use only. This warranty is void if the product is used in a commercial or institutional establishment.
4. This warranty does not cover normal wear and tear or damage caused by misuse, abuse, negligence, accident, acts of nature, or unauthorized modification or repair.
5. Purchaser must present acceptable proof of purchase for the product.
6. This warranty gives you specific legal rights, and you may also have other rights which vary from state to state.

Secura, Inc.  
[CustomerCare@thesecura.com](mailto:CustomerCare@thesecura.com)  
Lake Forest, California

# SECURA®

## Secura Bestsellers

Secura 60-Minute  
Visual Timer



Secura Electric  
Wine Opener



Secura Electric  
Soap Dispenser



Secura Premium  
Wine Aerator



Secura Electric Coffee  
and Spice Grinder



Secura Automatic  
Milk Frother



Duxtop Portable 1800W  
Induction Cooktop



Secura 1700W Electric  
2-in-1 Grill Griddle



Secura Triple Basket  
Electric Deep Fryer



Secura Electric  
Hot Air Fryer



Secura, Inc.

888-792-2360 (North America)

CustomerCare@thesecura.com

[www.thesecura.com](http://www.thesecura.com)

Lake Forest, California

For the fastest processing of a warranty claim, the owner should e-mail [CustomerCare@thesecura.com](mailto:CustomerCare@thesecura.com) and include the product name and model #, proof of original purchase, complete contact information, and detailed information about the issue, including pictures when applicable.